

# RECTANGULAR CHANNEL DETAIL

CP - SP305H / CP - SP308H /  
CP - SP312H / CP - SP414H

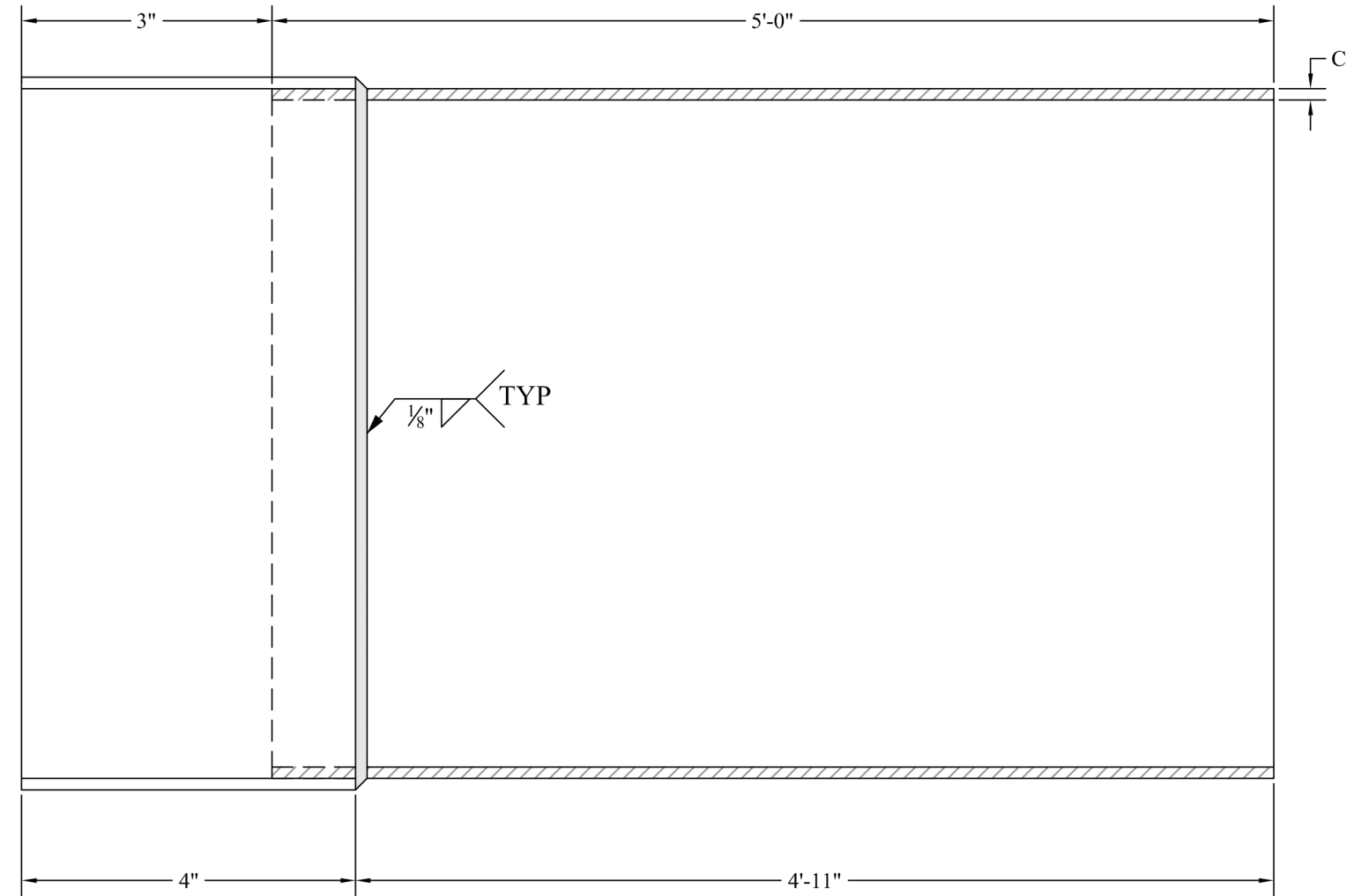
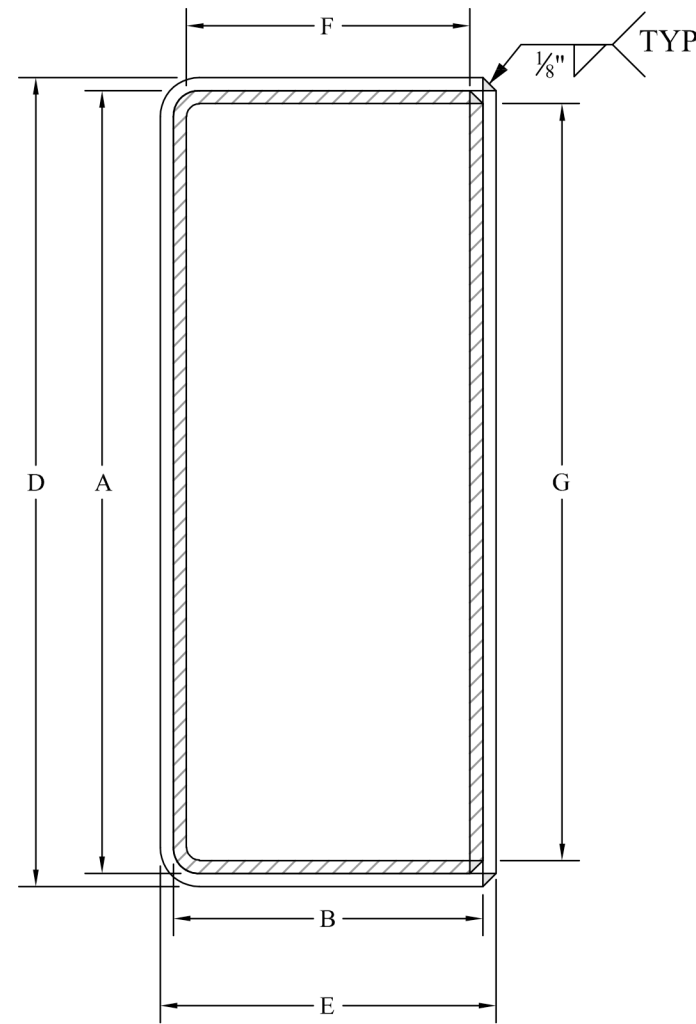

## PRODUCT SPECIFICATION - HUB PIPE

PRODUCT LIST				PRODUCT DIMENSIONS						
MODEL	DIMENSIONS	ROUND EQUIV.	ROUND TRANSVERSE AREA (SQ. IN.)	A	B	C	D	E	F	G
CP-SP305H	3" X 5" X 5'	4"	12.724	5.269"	3.269"	10 GA.	5.50"	3.5"	3"	5"
CP-SP308H	3" X 8" X 5'	5"	20.040	8.269"	3.269"	10 GA.	8.50"	3.5"	3"	8"
CP-SP312H	3" X 12" X 5'	6"	28.886	12.269"	3.269"	10 GA.	12.50"	3.5"	3"	12"
CP-SP414H	4" X 14" X 5'	8"	50.014	14.269"	4.269"	10 GA.	14.50"	4.5"	4"	14"

MATERIAL: 10 GAUGE GALVANIZED A653 G90 MEETS ASTM A-653. TENSILE STRENGTH 50,000 YIELD 36,000  
 ALL WELDS TO BE SPRAYED, ROLLED OR BRUSHED WITH GALVANIZED #95 COATING.  
 RECTANGULAR CONNECTION: MASTIC, CAULKING, EPOXY BINDING OR OTHER APPROVED METHOD.  
 ROUND CONNECTIONS: CAST IRON/PLASTIC PIPE CONNECTION, USE CAST IRON OR PLASTIC TO STEEL COUPLINGS.

NOTES	NOT TO SCALE		
FINISH	GALVANIZED		
DRAWN FOR:			
CURB-O-LET			
DESCRIPTION	RECTANGULAR CHANNEL DETAIL		
PROJECT NAME	CURB-O-LET		
DRAWN BY	FSV	JOB No.	DRG No.
DATE DRAWN	12/11/2018		S-01