

# RECTANGULAR CHANNEL DETAIL

APPROVED BY THE CITY OF LOS ANGELES  
BUREAU OF ENGINEERING/PUBLIC WORKS

CP - SP305H / CP - SP308H /  
CP - SP312H / CP - SP414H

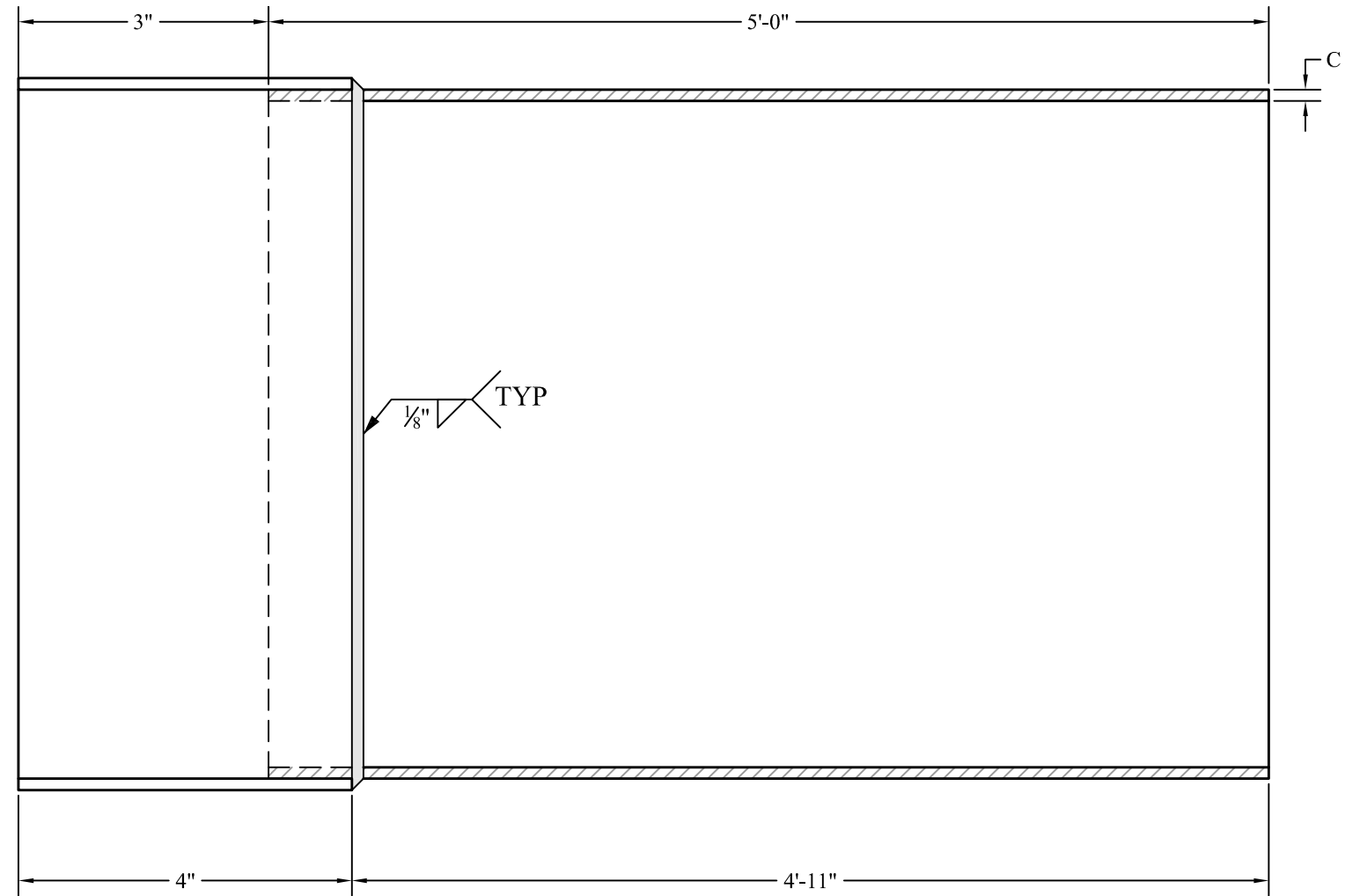
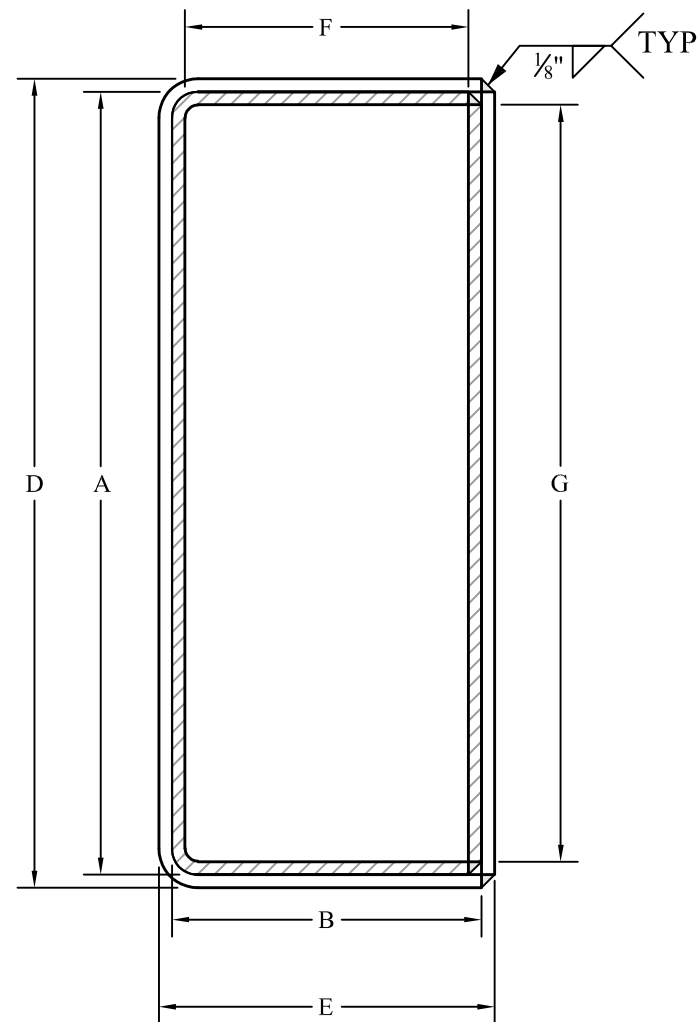

## PRODUCT SPECIFICATION - HUB PIPE

### PRODUCT LIST

### PRODUCT DIMENSIONS

MODEL	DIMENSIONS	ROUND EQUIV.	ROUND TRANSVERSE AREA (SQ. IN.)	A	B	C	D	E	F	G
CP-SP305H	3" X 5" X 5'	4"	12.724	5.269"	3.269"	10 GA.	5.50"	3.5"	3"	5"
CP-SP308H	3" X 8" X 5'	5"	20.040	8.269"	3.269"	10 GA.	8.50"	3.5"	3"	8"
CP-SP312H	3" X 12" X 5'	6"	28.886	12.269"	3.269"	10 GA.	12.50"	3.5"	3"	12"
CP-SP414H	4" X 14" X 5'	8"	50.014	14.269"	4.269"	10 GA.	14.50"	4.5"	4"	14"

MATERIAL: 10 GAUGE GALVANIZED A653 G90, MEETS ASTM A-653. TENSILE STRENGTH 50,000. YIELD 36,000. ALL WELDS WILL BE SPRAYED, ROLLED OR BRUSHED WITH GALVANIZED #95 COATING. RECTANGULAR CONNECTION: MASTIC (MUST MEET OR EXCEED ASTM D-4586), CAULKING, EPOXY OR OTHER CITY OF LOS ANGELES APPROVED METHOD. ROUND CONNECTION: CAST IRON/ PLASTIC PIPE CONNECTION USE CAST IRON OR PLASTIC TO STEEL COUPLINGS. CONTACT BUREAU OF CONTRACT ADMINISTRATION MATERIAL CONTROL SECTION AT (213) 485-5080 FOR FABRICATION INSPECTION

NOTES		NOT TO SCALE	
FINISH		GALVANIZED	
DRAWN FOR:			
			
DESCRIPTION		RECTANGULAR CHANNEL DETAIL	
PROJECT NAME		CURB-O-LET	
DRAWN BY	FSV	JOB No.	DRG No.
DATE DRAWN	12/11/2018		S-01

Curb-O-Let, Inc.  
9421 Monterey Ave.  
Bellflower, CA 90706