

# RECTANGULAR CHANNEL DETAIL

APPROVED BY THE CITY OF LOS ANGELES  
BUREAU OF ENGINEERING/PUBLIC WORKS

## CP - SP327H / CP - SP428H

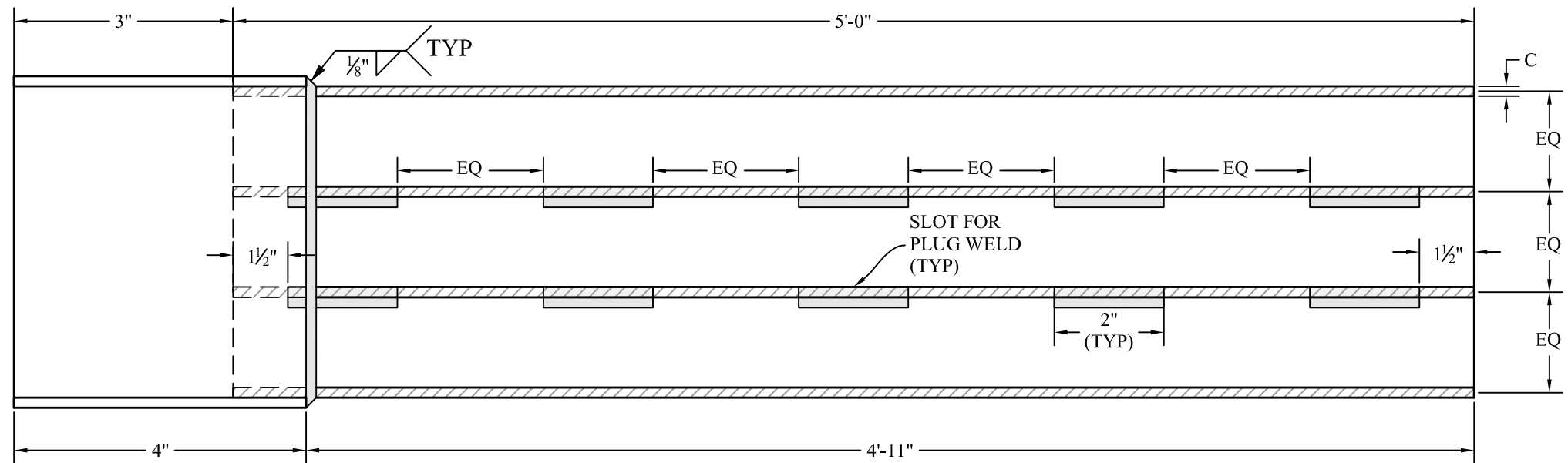
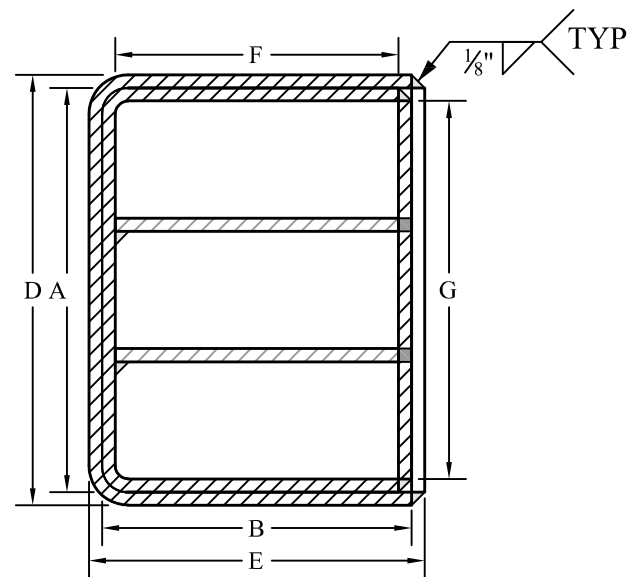

## CP - SP317H / CP - SP422H

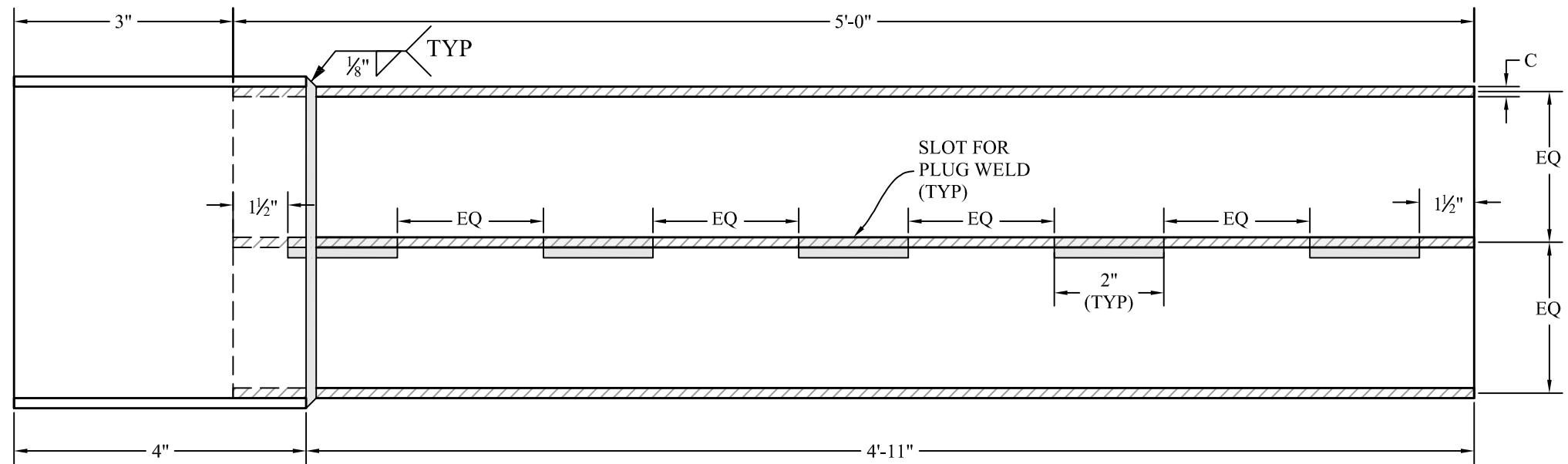
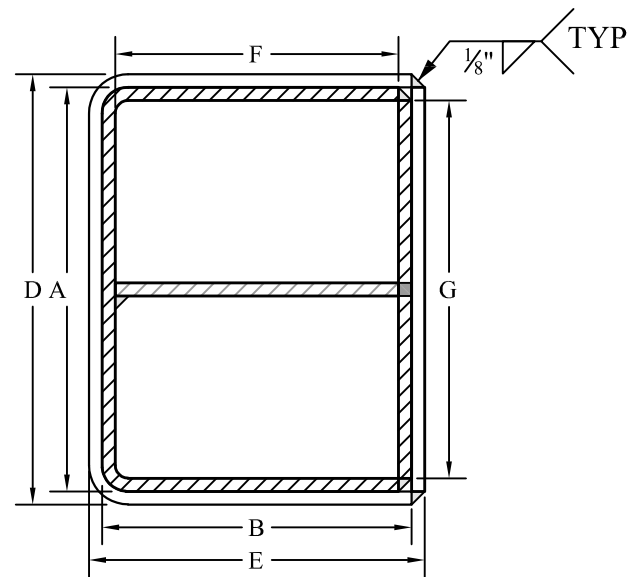

### PRODUCT SPECIFICATION - HUB PIPE

#### PRODUCT LIST

#### PRODUCT DIMENSIONS

MODEL	DIMENSIONS	ROUND EQUIV.	ROUND TRANSVERSE AREA (SQ. IN.)	A	B	C	D	E	F	G
CP-SP317H	3" X 17" X 5"	8"	50.014	17.269"	3.269"	10 GA.	17.50"	3.5"	3"	17"
CP-SP327H	3" X 27" X 5"	10"	78.814	27.269"	3.269"	10 GA.	27.50"	3.5"	3"	27"
CP-SP422H	4" X 22" X 5"	10"	78.814	22.269"	4.269"	10 GA.	22.50"	4.5"	4"	22"
CP-SP428H	4" X 28" X 5"	12"	113.097	28.269"	4.269"	10 GA.	28.50"	4.5"	4"	28"

MATERIAL: 10 GAUGE GALVANIZED A653 G90, MEETS ASTM A-653. TENSILE STRENGTH 50,000. YIELD 36,000. ALL WELDS WILL BE SPRAYED, ROLLED OR BRUSHED WITH GALVANIZED #95 COATING. RECTANGULAR CONNECTION: MASTIC (MUST MEET OR EXCEED ASTM D-4586), CAULKING, EPOXY OR OTHER CITY OF LOS ANGELES APPROVED METHOD. ROUND CONNECTION: CAST IRON/ PLASTIC PIPE CONNECTION USE CAST IRON OR PLASTIC TO STEEL COUPLINGS. CONTACT BUREAU OF CONTRACT ADMINISTRATION MATERIAL CONTROL SECTION AT (213) 485-5080 FOR FABRICATION INSPECTION

Curb-O-Let, Inc.  
9421 Monterey Ave.  
Bellflower, CA 90706

NOTES		NOT TO SCALE	
FINISH		GALVANIZED	
DRAWN FOR:			
			
DESCRIPTION		RECTANGULAR CHANNEL DETAIL	
PROJECT NAME		CURB-O-LET	
DRAWN BY	FSV	JOB No.	DRG No.
DATE DRAWN	12/11/2018		S-03