

APPROVED BY THE CITY OF LOS ANGELES
BUREAU OF ENGINEERING/PUBLIC WORKS

NOTES: UNLESS OTHERWISE SPECIFIED

1. MATERIAL: NOTED.
2. FINISH: AFTER ASSEMBLY.
3. ALL DIMENSIONS ARE IN INCHES UNLESS OTHERWISE SPECIFIED.
4. INSTALLATION: FOR 6 INCH CURB, INVERT OF CURB-O-LET TO BE 1/2 INCH ABOVE FLOW LINE ±1/4 INCH. FOR 8 INCH CURBS, BOTTOM OF CURB-O-LET TO BE INBEDDED IN CONCRETE ±1/4 INCH.
5. STAMP COMPANY NAME IN 1/2" HIGH LETTERS APPROXIMATELY WHERE SHOWN, .02-.04 DEEP.

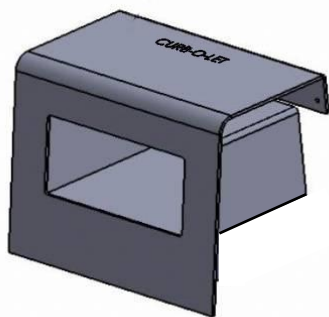
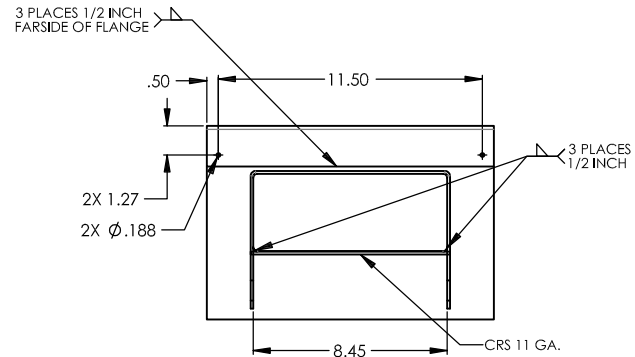
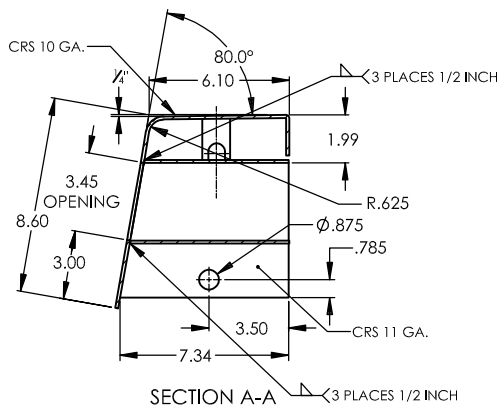
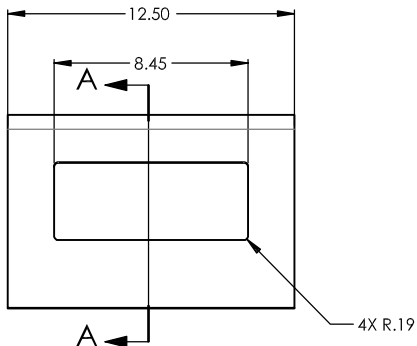
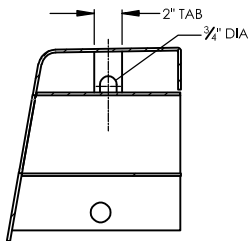

ITEM NO.	PART NUMBER	DESCRIPTION	QTY.
1	TCD38-NS	COVER	1
	INCLUDED	BRACKET	1
	INCLUDED	PLATE	1

UNLESS OTHERWISE SPECIFIED:
DIMENSIONS ARE IN INCHES
TOLERANCES:
FRACTIONAL ±
ANGULAR: MACH ± BEND ±
TWO PLACE DECIMAL ±
THREE PLACE DECIMAL ±

NAME	DATE	CURB-O-LET	
DRAWN D.C.	08/13/16	TITLE: TCD38-NS ASSEMBLY	
CHECKED		SIZE DWG. NO.	REV
ENG APPR.		C TCD38-NS	D
MFG APPR.		SCALE: 1:4	WEIGHT:
Q.A.		SHEET 1 OF 1	

Curb-O-Let, Inc.
9421 Monterey Ave.
Bellflower, CA 90706

