

APPROVED BY THE CITY OF LOS ANGELES  
BUREAU OF ENGINEERING/PUBLIC WORKS

NOTES: UNLESS OTHERWISE SPECIFIED

1. MATERIAL: NOTED.
2. FINISH: AFTER ASSEMBLY.
3. ALL DIMENSIONS ARE IN INCHES UNLESS OTHERWISE SPECIFIED.
4. INSTALLATION: FOR 6 INCH CURB, INVERT OF CURB-O-LET TO BE 1/2 INCH ABOVE FLOW LINE ± 1/4 INCH, FOR 8 INCH CURBS, BOTTOM OF CURB-O-LET TO BE INBEDDED IN CONCRETE ± 1/4 INCH.
5. STAMP COMPANY NAME IN 1/2" HIGH LETTERS APPROXIMATELY WHERE SHOWN, .02-.04 DEEP.

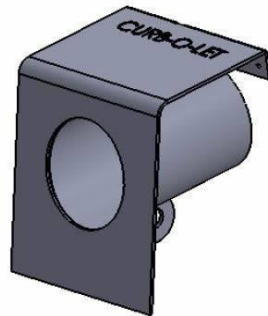
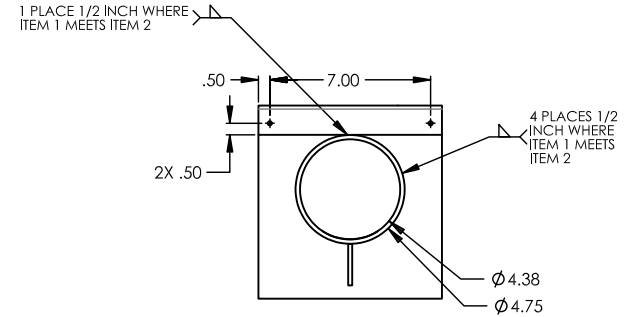
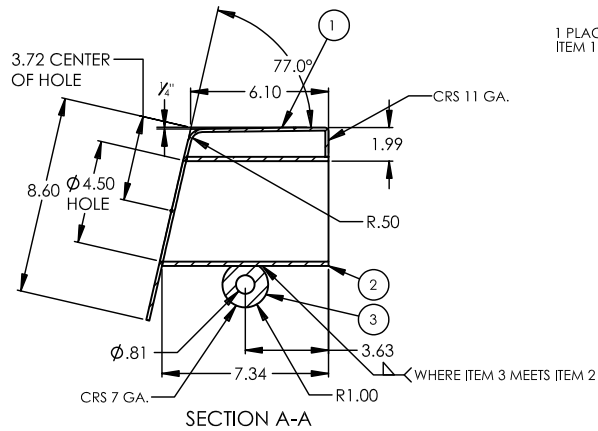
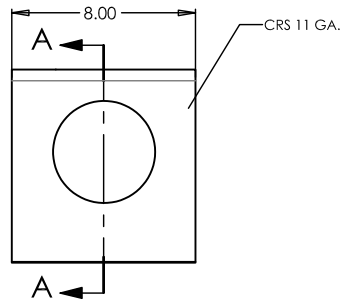

ITEM NO.	PART NUMBER	DESCRIPTION	QTY.
1	TCD4RD-NS	TOP	1
2	INCLUDED	TUBE	1
3	INCLUDED	WASHER	1

UNLESS OTHERWISE SPECIFIED: DIMENSIONS ARE IN INCHES TOLERANCES: FRACTIONAL ± ANGULAR: MACH ± BEND ± TWO PLACE DECIMAL ± THREE PLACE DECIMAL ±		NAME D.C.	DATE 08/13/16	CURB-O-LET	
DRAWN	CHECKED	ENG APPR.	MFG APPR.	TITLE: TCD4RD-NS ASSEMBLY	
Q.A.				SIZE C	DWG. NO. TCD4RD-NS
				SCALE: 1:4	REV D
				WEIGHT:	SHEET 1 OF 1

Curb-O-Let, Inc.  
9421 Monterey Ave.  
Bellflower, CA 90706

